

# Deep Space Navigation

Lecture prepared with the assistance from Bob Mase and Dave Spencer (JPL)

# The Mission Design and Navigation Process

- The deep space mission design and navigation process consists of trajectory design, orbit determination and maneuver design.
  - ⇒ Trajectory design: obtain a map, plot a course (BMW Chap. 4 and 5)
  - ⇒ Orbit determination: take measurements, calculate position (BMW Chap. 2)
  - ⇒ Maneuver design: make course corrections (BMW Chapter 3)

# The Navigation Process

- Five tasks need to be performed for successful navigation, whether on Earth or in deep space:

<u>Task</u>	<u>Student Example</u>	<u>Deep Space Example</u>
1. Obtain a map	Log onto Mapquest	Planetary ephemerides
2. Plot a course	Find route to Spring Break destination	Select target body, compute launch/arrival conditions
3. Take measurements	Speedometer, odometer in-car GPS	Radiometric tracking data, pictures of target & star background
4. Calculate position	Read road signs, GPS	Numerical least-squares fit of tracking data
5. Make course corrections	Turn the wheel, hit the gas pedal or brakes	Perform propulsive maneuver

# Navigation Uncertainty - Analogy

- If you know where you are, and where you need to get to, why do you need navigation?
  - *Problem:* Your friend wants to meet you in Florida at your Spring Break destination just as you arrive with a cold beverage
  - *Solution:* If you start out in Atlanta, heading to Spring Break destination, know what time you are leaving, and the speed limit, you can calculate exactly when you should arrive... or can you?
  - What if there is an accident, or traffic jam, or you stop for gas or food?  
What if your odometer is off by 2 miles/hour?  
What if the street signs are poor and you take a wrong turn?
    - Can you predict these things exactly ahead of time?
  - How can we account for unseen events ahead of time to compensate?
    - I'll be there at 5:00 *plus or minus an hour*
    - No good: *Cold beverage will get warm waiting one hour in the hot Florida sun!*
    - Solution : Cellphone! - Call with a late knowledge update when you get close

# Navigation Uncertainty

- How does this example apply to deep-space navigation?
  - True there are no traffic jams or pit-stops in space...  
But what can affect the trajectory?
  - Do we know all propulsive events that will happen?
  - Do we know all forces that will act on the spacecraft?
  - Do we know all of our measurements are exactly right?
  - Do we know exactly where our target is?
  - Do we know exactly where we are?

# Deep Space Example

- Typical trajectory to Mars is about 250 days
  - 250 days x 86,400 sec/day = 21,600,000 s
- Typical propulsive maneuver will impart on the order of 1 to 10 m/s of velocity change to the spacecraft
  - We can measure the velocity change to within 1 mm/sec
- If we are wrong by only 1 mm/sec and use a simple linear calculation:

$$\begin{aligned}\text{Distance} &= \text{Velocity} * \text{Time} \\ 1\text{E-6 km/sec} * 21,600,000 \text{ sec} &= 21.6 \text{ km}\end{aligned}$$

We will arrive 21.6 km off from where we should be.

# Trajectory Design

- Trajectory design is the process of developing flight paths that meet mission constraints, such as:
  - Launch energy within capabilities of launch vehicle for maximum expected launch mass
  - Time of flight consistent with spacecraft design and ops costs
  - Arrival velocity within vehicle capability for orbit insertion burn or atmospheric entry
  - Local time of landing site or orbit node orientation within limits for power subsystem and science instruments
  - Entry flight path angle uncertainty allows target landing ellipse to be met, to high confidence
- For a given opportunity, launch targets are typically defined as:
  - Launch energy (C3), declination and right ascension
- For landers, arrival conditions are targeted at the atmospheric interface point (125 km altitude for Mars):
  - Radius, entry flight path angle, B-plane angle, time
- For orbiters, arrival conditions are typically defined as:
  - Radius of periapsis, inclination, time

# The B-Plane

- Navigators often use the B-Plane to describe the arrival trajectory relative to the target body.
  - The B-Plane is defined perpendicular to the incoming asymptote of the trajectory.
  - The “B-Vector” extends from the center of the target body to the point where the incoming asymptote intersects the B-Plane. Offset distance ( $\Delta$ ) is the two-dimensional depiction of the B-Vector (along the T-axis).
  - The S-direction is defined // to  $V_{inf}$
  - The T-direction is often defined in the mean equatorial plane of the target body
  - The R-direction is down, such that  $R \times S = T$
  - Arrival conditions are expressed as:  $B \cdot R$ ,  $B \cdot T$ , and TOF.
  - The B-Plane angle is the angle from the +T direction to the B-vector.

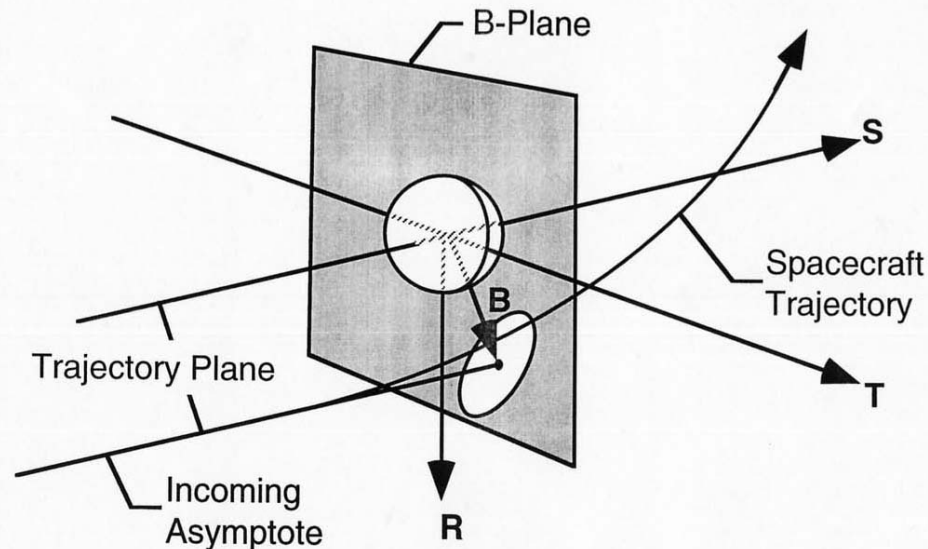

# Forces That Impact the Trajectory

The translational motion of a spacecraft is influenced by a number of different forces:

- Gravitational forces
  - Central body force (the Sun for interplanetary trajectories)
  - Third-body forces (Jupiter, other planets, moons)
  - Gravity field asymmetries (while in orbit)
- Non-gravitational forces
  - Thruster firings (trajectory control and attitude control)
  - Solar radiation pressure
  - Aerodynamic drag (while in orbit)
  - Outgassing & gas leaks

All of these forces result in accelerations that are modeled and integrated over time to estimate the spacecraft trajectory.

For the heliocentric portion of an Earth-Mars transfer, the largest forces are due to:

- (1) Sun's gravity
- (2) Solar radiation pressure
- (3) Jupiter's gravity
- (4) Other planets gravity

# Deep Space Example

- Acceleration due to solar radiation pressure
  - Typical uncertainty is on the order of 1E-12 km/s/s
  - If we are wrong by only 1E-12 km/s/s:

$$\text{Distance} = 1/2 * a * t^2$$

$$1/2 * (1\text{E-}12 \text{ km/s/s}) * (21,600,000 \text{ s})^2 = 230 \text{ km}$$

We will arrive 230 km off from where we should be

**Note:** This uncertainty will decrease with time to go

- The closer we get to the target, the number of things that can happen between now and arrival decreases
- The effect of any individual perturbation also decreases with time to go

# Maneuver Design

- Maneuver design involves the calculation of course corrections ( $\Delta V$ s) at specified points along the trajectory, so that the target conditions are met.
  - Starts with the best-fit trajectory solution from the OD team.
  - Utilize high-fidelity trajectory propagation model
- Preliminary maneuver designs are often based upon “instantaneous”  $\Delta V$ s. Final maneuver designs account for “finite burn” effects, which can be significant for large maneuvers such as orbit insertion.
- Maneuver analysts also budget the spacecraft propellant, accounting not only for “deterministic”  $\Delta V$  (assuming ideal maneuver performance), but “statistical”  $\Delta V$  (including OD uncertainties and maneuver execution errors).

# Orbit Determination

- Orbit determination (OD) is the process of adjusting the modeled trajectory to best fit the observed tracking data, and quantify the uncertainty associated with the trajectory estimate (see BMW Ch 2)
  - Collected tracking data are the actual or *Observed* measurements
  - Trajectory models produce predicted or *Computed* measurements
  - *Data Residuals = Observed – Computed*
- The OD process is to minimize residuals by adjusting the trajectory model to minimize residuals in a weighted least-squares sense. The OD “filter” accounts for measurement uncertainties associated with various error sources related to the spacecraft, the tracking station, the Earth itself, and the atmosphere.
- Assessment of the OD solution is subjective, and is both art and science.
  - Are there any trends to the residuals resulting from modeling inaccuracies
  - Artificially constrained parameters (overly optimistic a-priori uncertainty) can constrain the filter estimate, lead to an erroneous trajectory result or unrealistically small uncertainty (MCO).

# Orbit Determination (cont.)

Simulated Doppler residuals. Lack of noticeable trend and zero mean on residuals indicates that trajectory model agrees well with tracking data.

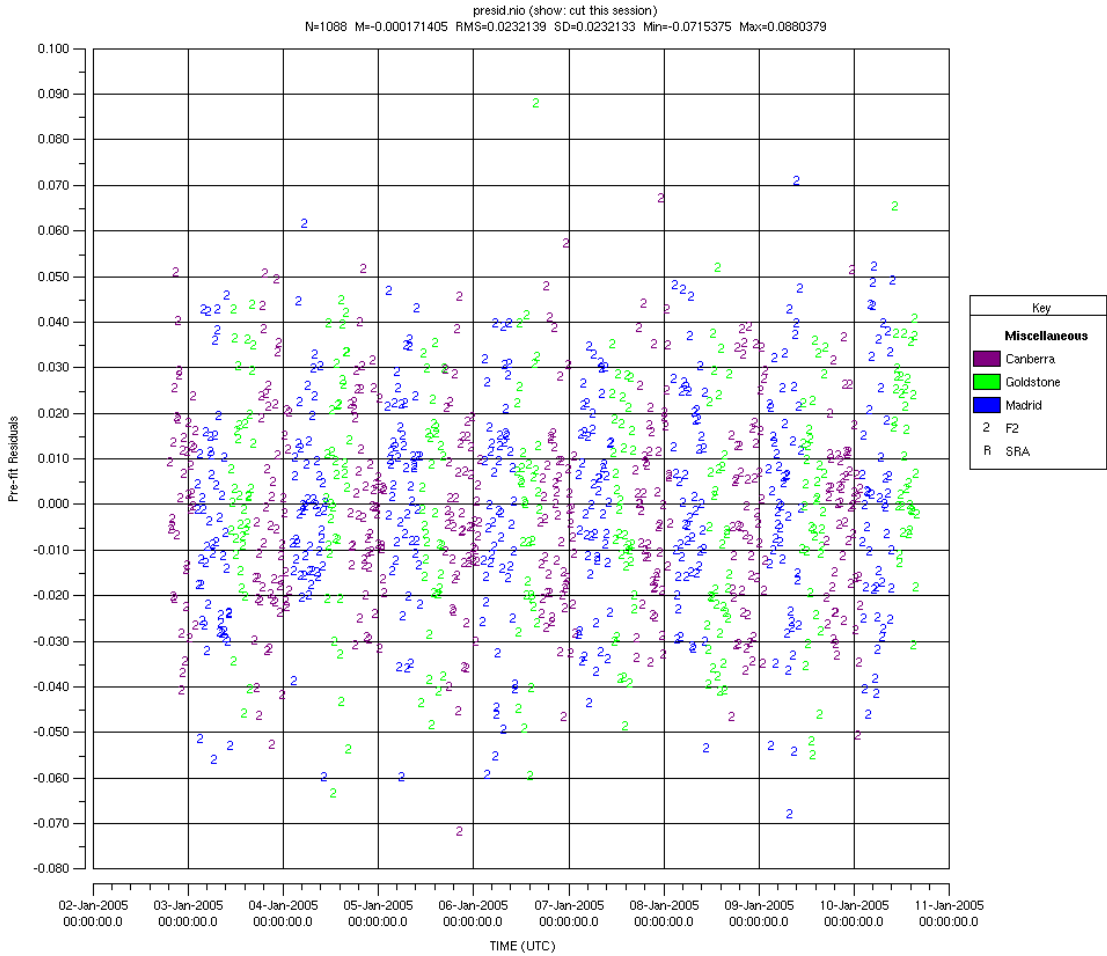

# Error Sources

What other error sources do we have to contend with?

- Measurement Errors:
  - Measurement noise
  - Earth orientation
  - Tracking station locations
  - Transmission media
  - Instrumental signal delay effects
  - Spacecraft oscillator instability
- Force Modeling Errors:
  - Gravity
  - Propulsive maneuver events
  - Solar radiation pressure
  - Outgassing
- None of these things are known exactly, so we must account for our lack of knowledge by calculating the associated uncertainty

# Navigation Uncertainty

What strategy can we use to account for uncertainty or errors?

- We always have the ability to adjust the trajectory - fire the thrusters
- Small adjustments *early* in the trajectory have a bigger effect
  - Can change travel time significantly by driving slightly faster all the way
  - This will change the planned arrival time, but will not decrease the uncertainty in what time you will actually arrive
- Adjustments at the last minute more precise, but limited in scope
  - If you wait until you are almost there, there is not much left to deter you
  - Can't significantly change arrival time just one mile from your destination
- We schedule a series of opportunities to adjust the trajectory consistent with our knowledge of the trajectory and associated uncertainty
- Make big adjustments early to get in the ballpark, make more precise adjustments later when there is more certainty in arrival conditions

# Navigation Measurements

What measurements do we have to work with?

- **Range** - Measures the line-of-site *distance* from the spacecraft to the tracking station
  - Typically accurate to a couple of meters
- **Doppler** - measures the line-of-site *velocity* between the spacecraft and the tracking station
  - Typically accurate to 0.1 mm/sec (0.0002 mph !)
- Can measure position and velocity quite accurately
  - But only in one direction
- On Earth we have handheld GPS which uses 4 or more satellites to unambiguously triangulate your location
  - For spacecraft, we can use two tracking stations at once to triangulate, referred to as an *interferometric* measurement ( $\Delta$ DOR)

# Navigation Data Types

- During interplanetary cruise, the JPL navigation team uses several different techniques to track the spacecraft's position and speed through the DSN.
  - Doppler and ranging are the two most common techniques
- In ranging, a signal is sent from Earth to the s/c and the s/c sends a signal back to Earth. By measuring precisely how long the signal takes to make the round trip at the speed of light, the spacecraft's distance from Earth along the line of sight can be determined.
- In two-way Doppler tracking, a ground station sends a signal to the s/c and the s/c sends a signal back to Earth. By looking for small changes in the frequency of the spacecraft's signal, the s/c velocity along the Earth line of sight can be determined (radial velocity).
  - Spacecraft right ascension and declination can also be obtained by observing the effect of Earth rotation on the signal. However, the out of plane velocity component can not be obtained.
  - The signal's frequency changes with the spacecraft's speed, much like the rising and falling of the siren of a fire truck or train as it passes by.
- For the Odyssey and MER missions, an additional technique, "delta differential one-way range," or  $\Delta$ DOR was employed. In this technique, two different ground stations on Earth simultaneously measure signals from the s/c and from one of several distant quasars in space. Like beacons in the cosmos, quasars provide very stable radio signals. By combining the measured signals using interferometry (VLBI), navigators measure the s/c's angular motion relative to Earth. These measurements provide insight into the "plane of sky" s/c motion.

# Small Forces Can Have a Large Effect

Navigation accuracy is also negatively impacted by the mis-modeling of “small forces” that impact the spacecraft trajectory.

*Solar Radiation Pressure* Solar radiation pressure exerts a small but significant force on the spacecraft. If left uncorrected, solar pressure would alter the course of a typical spacecraft on an Earth-to-Mars trajectory by tens of thousands of kilometers.

*Reaction Wheel Desaturations* For three-axis stabilized spacecraft using reaction wheels, momentum builds up in the wheels over time, requiring periodic thrusting events to despin, or “desaturate” the wheels. These thrusting events must be carefully modeled in the orbit determination process.

*Outgassing* In the extreme temperatures and vacuum of space, materials on the spacecraft that had accumulated moisture on Earth will outgas. Outgassing is quite noticeable in the navigation solutions for the initial 1-2 weeks following launch.

# Mars Climate Orbiter



- On September 23, 1999 the Mars Climate Orbiter (MCO) burned up in the Mars atmosphere while attempting orbit insertion.
  - During cruise, the three-axis stabilized MCO performed reaction wheel desaturations 15-20 times per week, a rate several times that predicted pre-launch.
  - During cruise, the MCO navigation solutions migrated beyond the statistical uncertainties calculated in the orbit determination solutions.
  - The navigation team expressed concern, and worked with the spacecraft team to resolve inconsistencies in the reaction wheel desaturation modeling.
  - The interface agreement between the spacecraft team (at Lockheed Martin in Denver) and the navigation team (at JPL in Pasadena) specified that the thrusting events associated with reaction wheel desaturations would be provided in metric units. The “small forces packet” contained in spacecraft telemetry reported the thrusting events in English units. The proper conversion to metric units was not performed by the spacecraft team prior to sending the small forces file to the navigation team.
  - The navigation team recommended that TCM-5 be executed to raise the periapsis altitude for the insertion burn a day prior to arrival. The operations team had not rehearsed performing this maneuver on a shortened timeline, and the mission manager denied the navigators’ request.
  - MCO reached a periapsis altitude of approx. 50 km, well within the Mars atmosphere.

## MCO Nav Solutions Mapped to B-Plane Pre-TCM-4 (3-Sigma Ellipses)

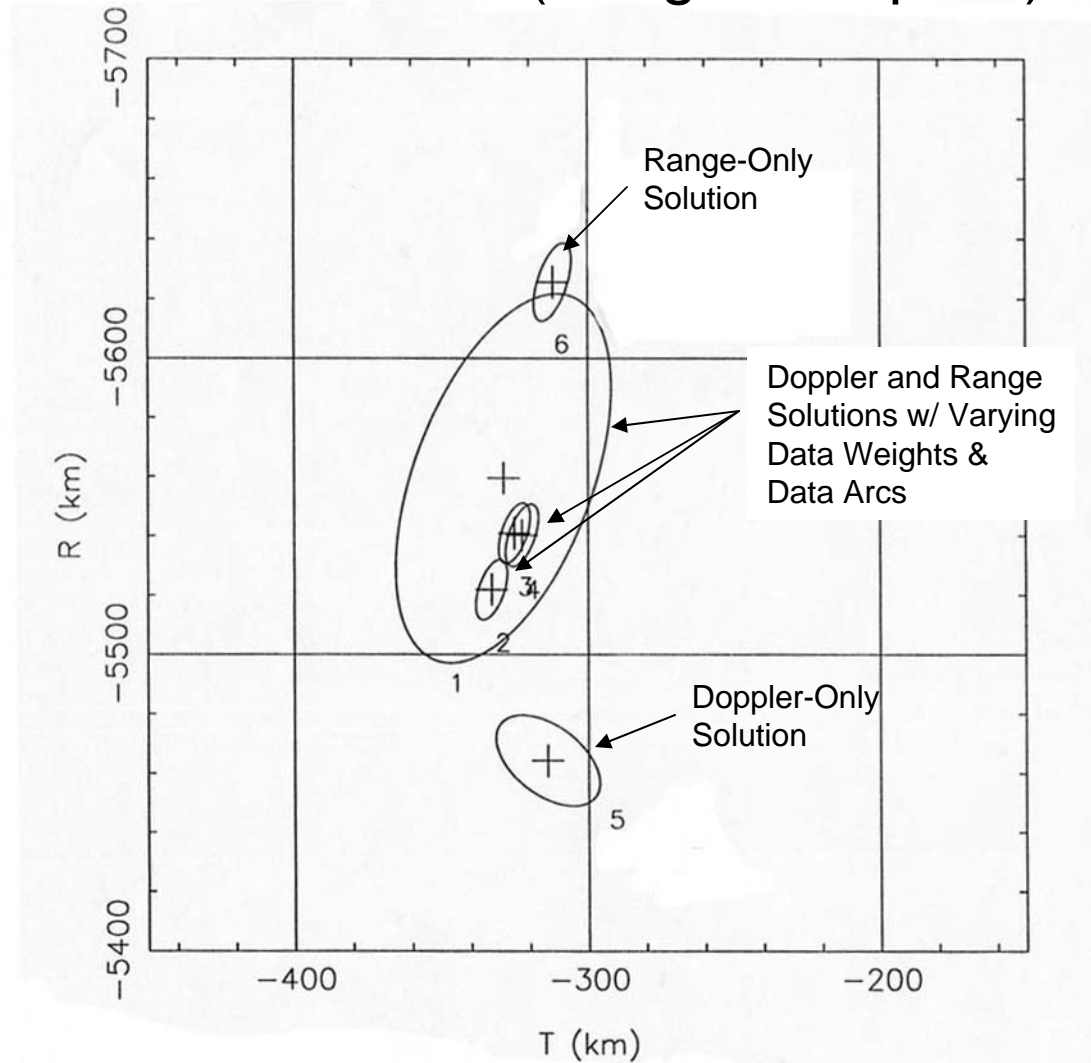

Note: Poor agreement between solutions with different data types.



# IN-FLIGHT RESULTS

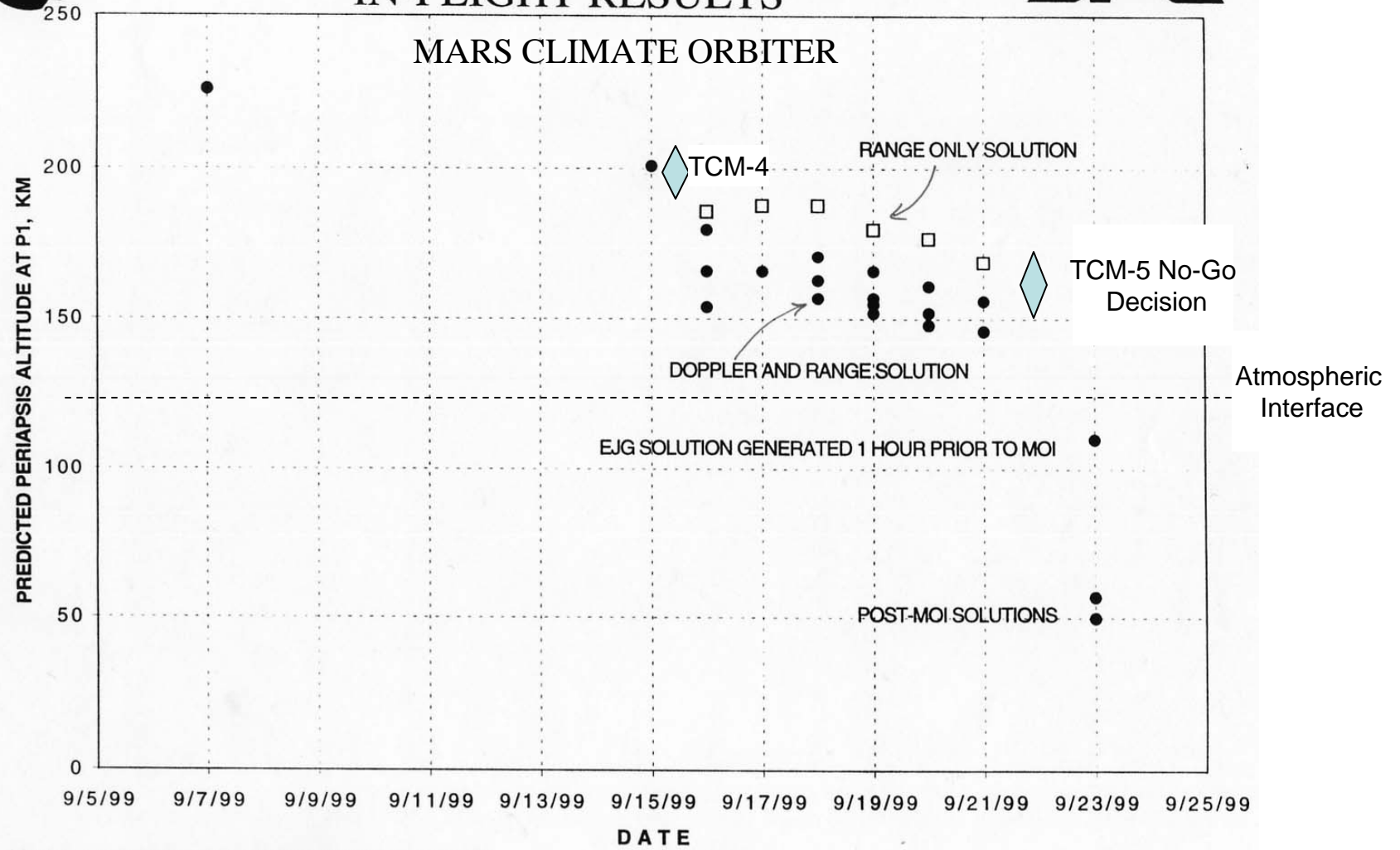

NASA MCO FAILURE INVESTIGATION BOARD

10/18/99

PBE/EG-16



## Mars Odyssey and MER: Setting A New Standard in Navigation Accuracy

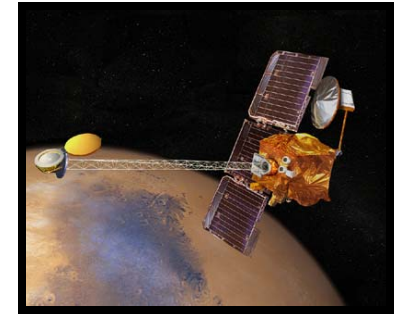

- Following the MCO and MPL failures, the Mars program underwent significant review and evaluation
- The JPL navigation process has been strengthened by inclusion of an independent advisory group (NAG), a focus of uncertainty and better communication with the spacecraft team, systems engineers and project managers.
- By combining range, Doppler and  $\Delta$ DOR measurements:
  - In 2001, Odyssey achieved its target altitude for orbit insertion to within 1 km
  - At the time of orbit insertion, Odyssey had traveled 457 million kilometers. The Mars Odyssey navigation team won a Laurel in the space category for Aviation Week & Space Technology magazine's 2001 awards.
  - In 2004, Both MER spacecraft landed within 15 km of their targets, even with the uncertainties associated with Mars atmospheric entry and winds during the parachute phase. Navigation uncertainty at the top of the atmosphere was within 200m of the target.

# Mars Odyssey

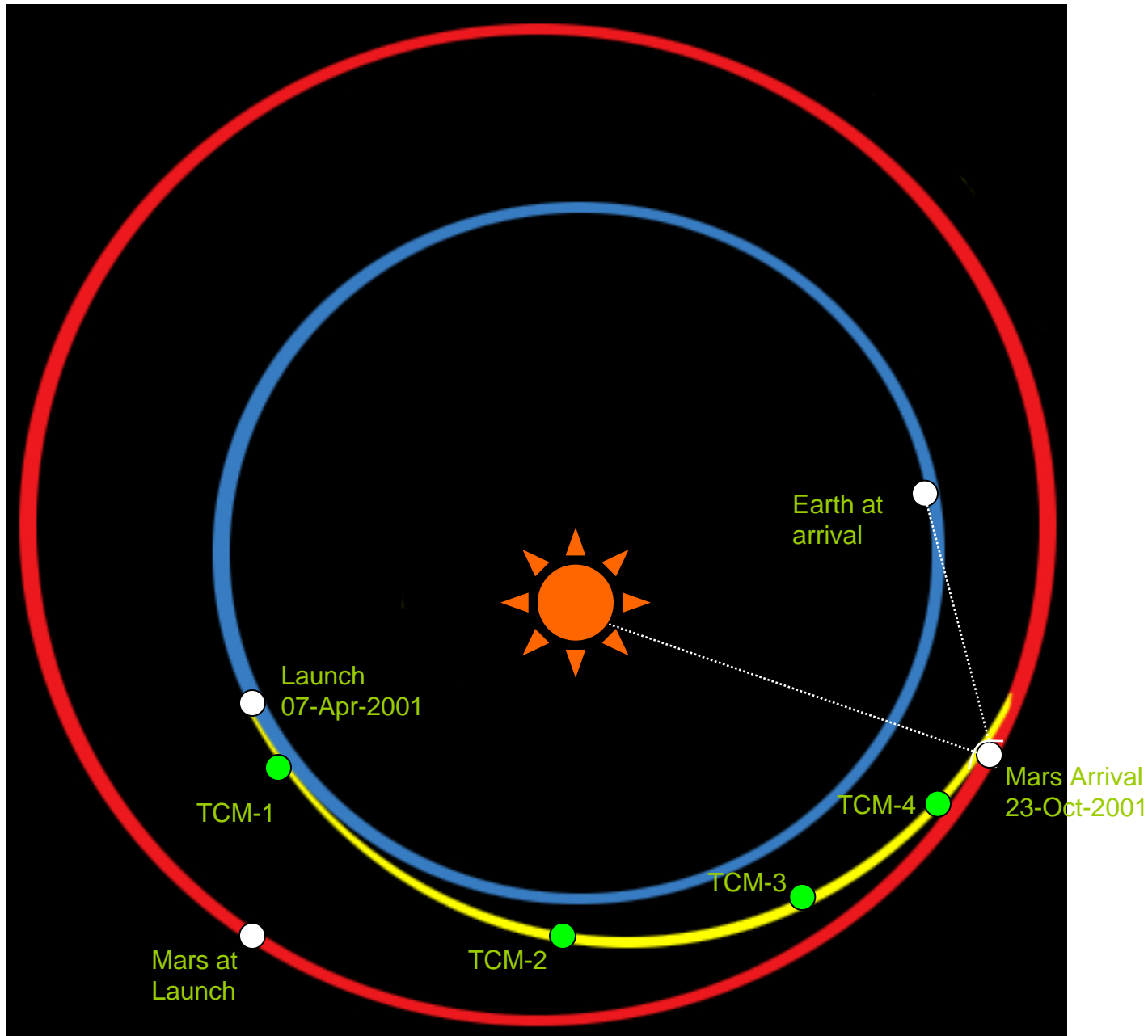

# Mars Odyssey - Launch

- If the spacecraft was launched and never performed any kind of trajectory correction maneuver, where would it end up?

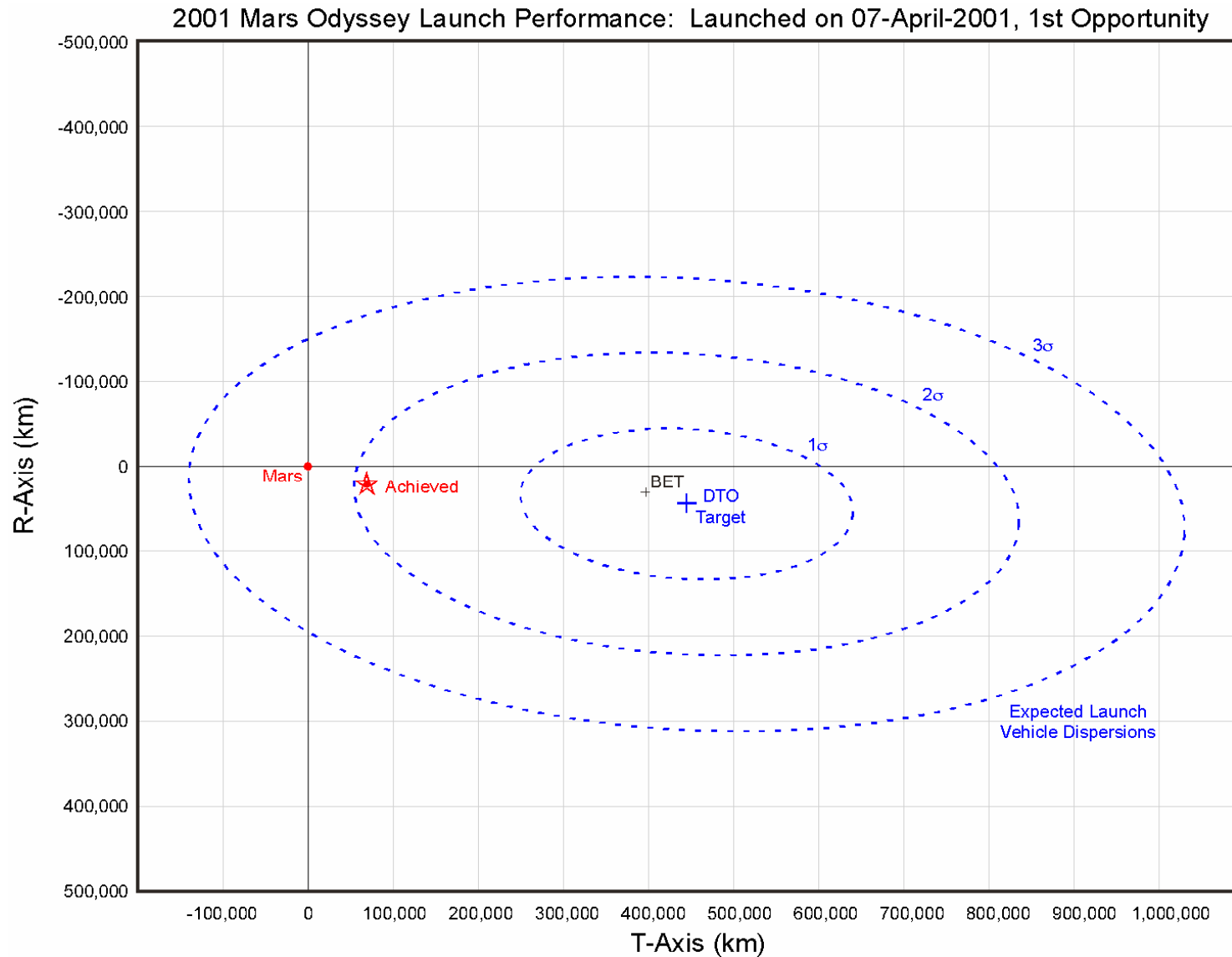

# Mars Odyssey - First Maneuver

- The first propulsive maneuver: 3.6 m/s, 46 days after launch
  - Moved arrival point 60,000 km closer to Mars
  - Still large uncertainty ( $> 1000$  km) in expected arrival conditions

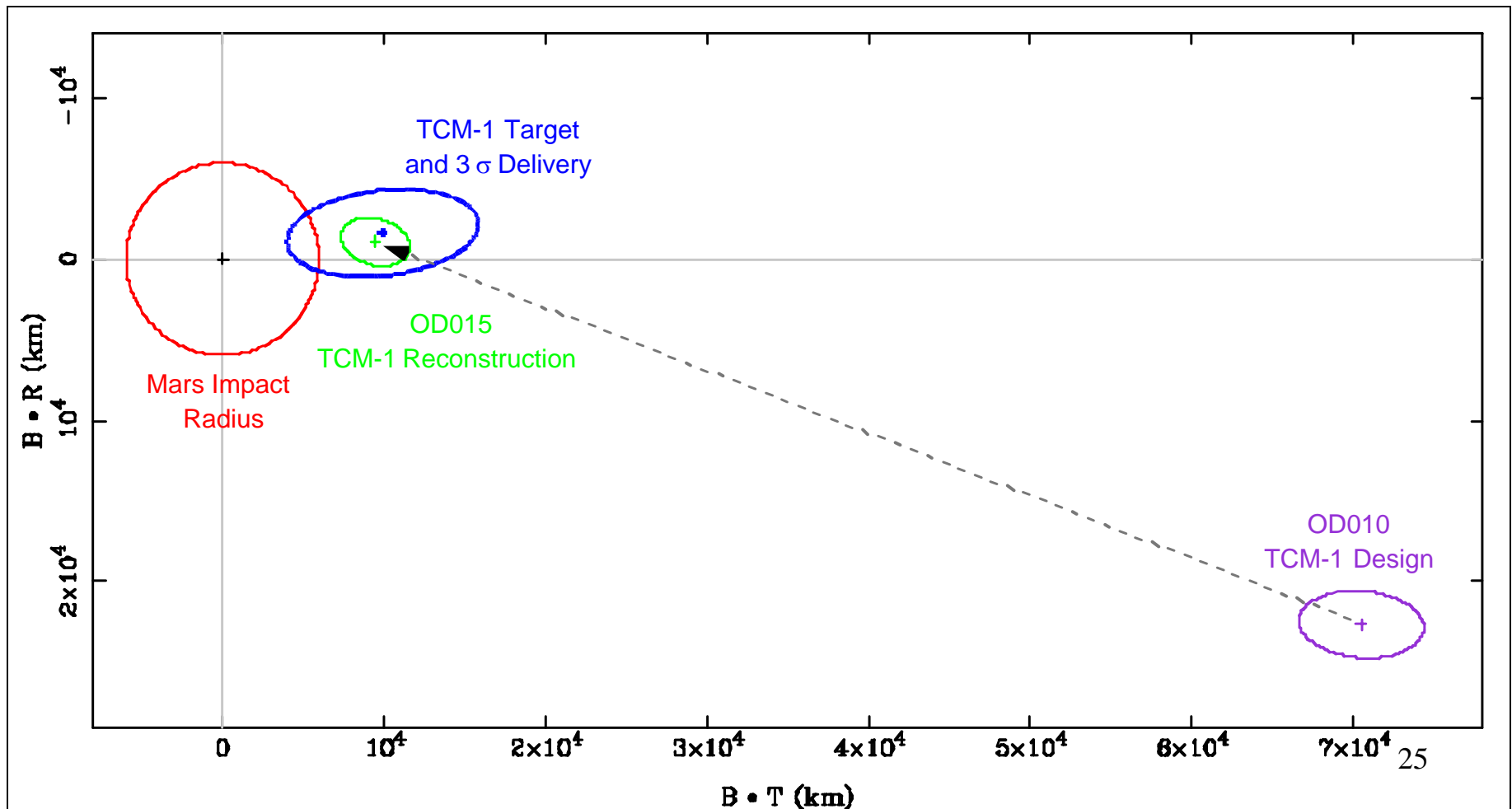

# Mars Odyssey - Final Maneuver

- The final maneuver: 0.08 m/s, 12 days prior to arrival
  - Needed to be accurate to  $\pm 25$  km, ended up  $< 5$  km from the target

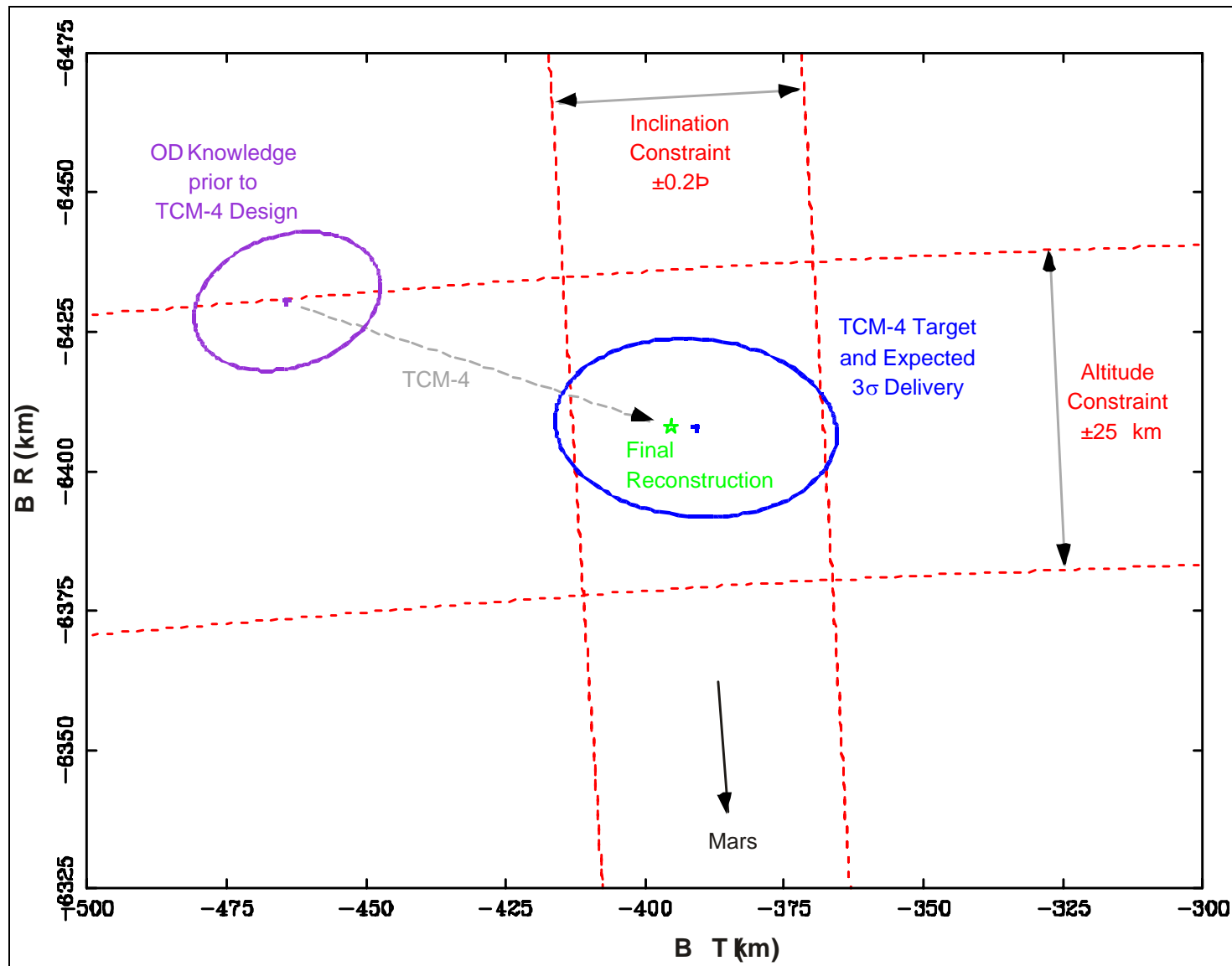

# Mars Exploration Rovers

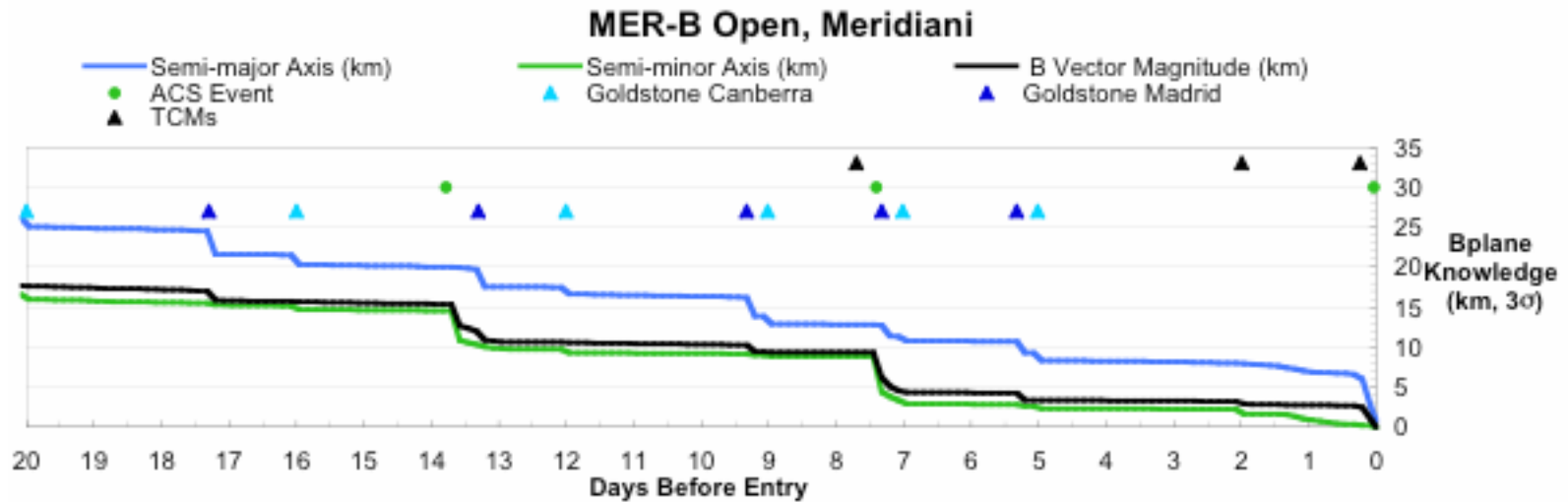
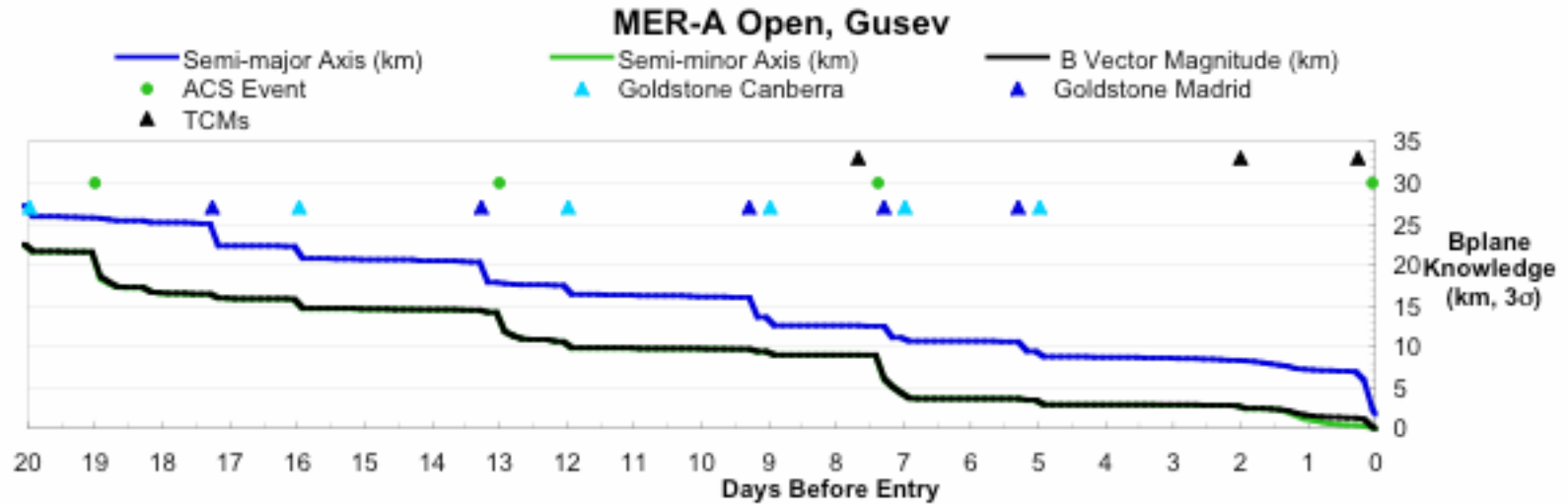

# Backup

# Definition of Spacecraft and Station Coordinates

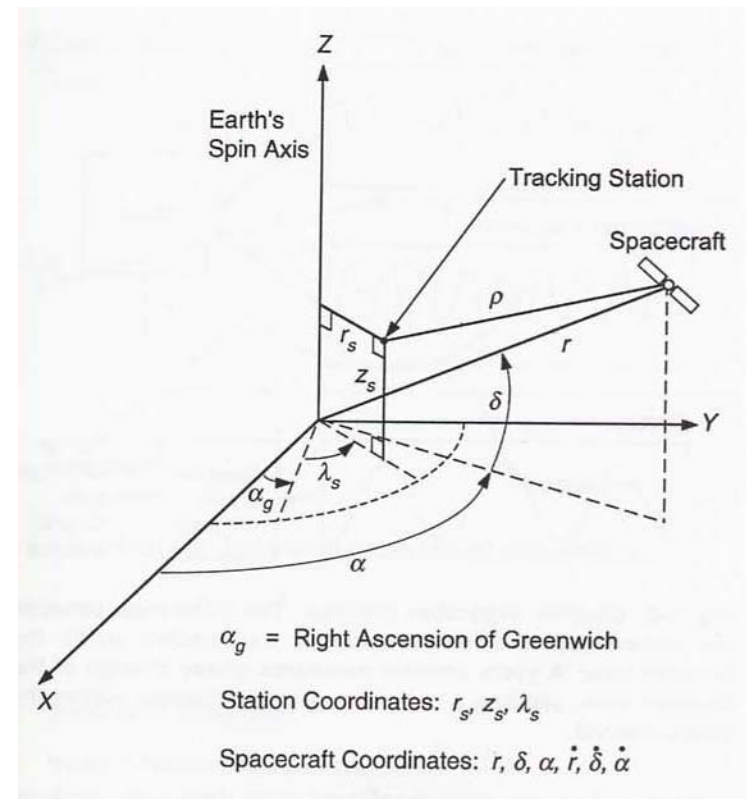

- $r$  = spacecraft range from the center of Earth
- $\rho$  = spacecraft slant range from tracking station
- $\alpha$  = spacecraft right ascension with respect to the vernal equinox
- $\delta$  = spacecraft declination with respect to Earth Mean Equator

# Ranging

- Spacecraft range is measured by the round-trip transit time of a ranging signal generated at one of the DSN stations, to the spacecraft, and returned to Earth.
  - A ranging signal consists of a sequence of sinusoidal tones phase-modulated onto a carrier signal.
  - The spacecraft receiver locks on to the ranging signal and turns around a downlink signal.
  - The received downlink signal at the DSN is demodulated, and the received “range code” is compared with the uplinked range code to compute round-trip transit time. The round-trip transit time,  $\tau$ , can be divided by two times the speed of light,  $c$ , to find the one-way slant range,  $\rho$ :

$$\rho = \tau / 2c$$

- In practice,  $\tau$  is computed from  $t$  (the measured roundtrip time) by subtracting a known and calibrated  $\varepsilon$  (spacecraft process time)

# Doppler

- An expression for the received frequency of a signal sent from a receding spacecraft to Earth is:

$$f_R = (1 - \dot{\rho} / c) f_T$$

where  $f_T$  is the frequency transmitted by the spacecraft and  $\dot{\rho}$  is the spacecraft instantaneous slant range rate.

- The quantity  $(\dot{\rho} / c) f_T$  is referred to as the Doppler shift.
- The Doppler measurement provides information on the spacecraft slant range rate.

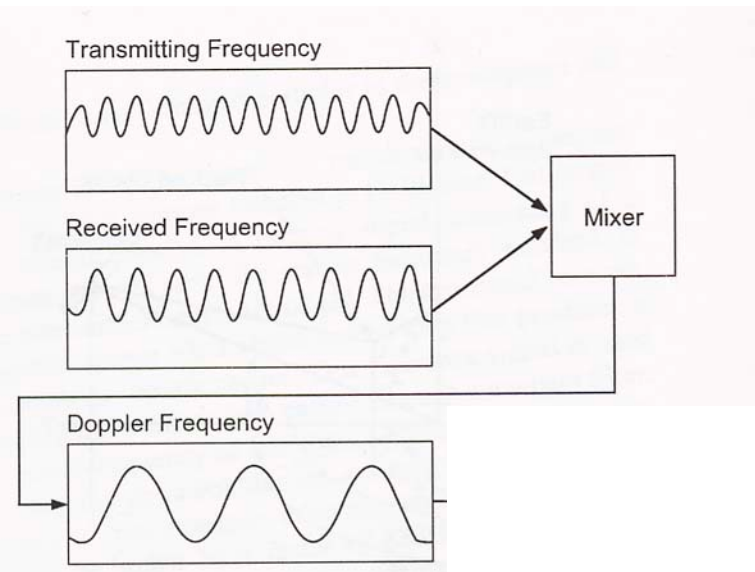

## Doppler (cont.)

- For a receding spacecraft, the slant range rate calculated by the equation on the previous page is a sinusoid superimposed upon a ramp function representing the spacecraft geocentric velocity.
  - The diurnal sinusoid behavior is the result of the rotation of the tracking station about the Earth's spin axis.
  - The amplitude and phase of this sinusoid provide information about the spacecraft declination and right ascension.
  - From a single pass of Doppler data, it is possible to determine the spacecraft radial velocity, right ascension and declination. Velocities normal to the line of sight can be *inferred* from several days of Doppler data.

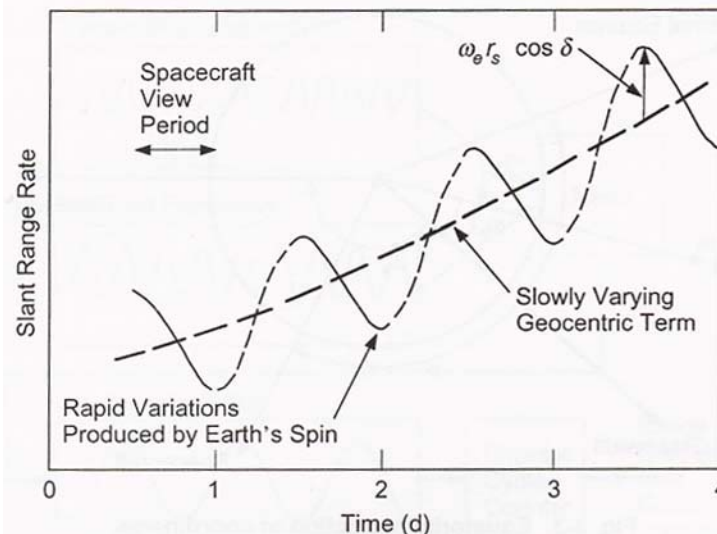

# Angular Measurements

- For most interplanetary missions, spacecraft position uncertainty is much smaller in the Earth-to-spacecraft “radial” direction than in the perpendicular “plane-of-sky” direction.
  - Radial components of position and velocity are directly measured by range and Doppler observations.
  - Plane-of-sky errors are more than 1000 x radial errors, even under the most favorable conditions, using only ranging and Doppler.
- In general, angular measurements can be made using multiple ground stations to simultaneously receive spacecraft transmissions during DSN view period overlaps.
  - From an accurately known baseline,  $B$ , and a calculated delta slant range distance,  $\rho_2 - \rho_1$ , one can compute the spacecraft declination,  $\delta$ . (VLBI)

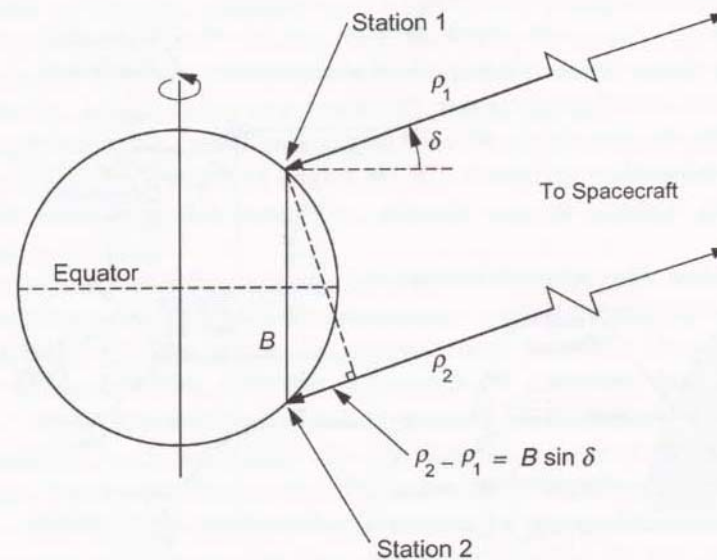

# $\Delta$ DOR

- Delta Differential One-Way Range ( $\Delta$ DOR) is a VLBI measurement technique that utilizes two ground stations to simultaneously view the spacecraft and then a known radio source (quasar or another spacecraft) to provide an angular position determination.
  - Two stations receiving the same ranging signal allows a geometric plane-of-sky angular position measurement (Differential), as shown on the previous slide.
  - By receiving signals from two sources, common errors can be canceled out, allowing a precise measurement of the angular separation of the two radio sources (Delta).
  - Since the plane-of-sky angular position of the quasar is well known, the plane of sky angular position of the s/c can be determined
  - $\Delta$ DOR is a particular type of Very Long Baseline Interferometry (VLBI), that has been used for several decades on deep space missions.
  - Recent application of  $\Delta$ DOR with upgraded equipment at the DSN has enabled unprecedented navigation accuracy on the Mars Odyssey and Mars Exploration Rover missions.

# Tracking Stations: The Deep Space Network

- Communications between Earth-based tracking stations and spacecraft are made within internationally allocated frequency bands:

Band	Uplink Frequency (MHz)	Downlink Frequency (MHz)	Application
S	2110 - 2120	2290 - 2300	L/V upper stage
X	7145 - 7190	8400 - 8450	Most Mars missions
Ka	34,200 - 34,700	31,800 - 32,300	MRO

- Deep Space Network (DSN) tracking stations are located at Goldstone, California; Canberra, Australia; and Madrid, Spain.
  - The DSN provides radiometric tracking for all deep space spacecraft.
  - The DSN stations are spaced evenly around the globe, allowing consistent tracking for spacecraft near the Earth's equatorial plane.
  - Spacecraft at high southerly declinations may have coverage over Canberra only.
  - Each DSN station has multiple antennas, with diameters ranging from 26 m to 70 m.