

## AE3051 Experimental Fluid Dynamics

### OPTICAL/PRESSURE MEASUREMENTS IN SUPERSONIC FLOW

#### Objective

This lab covers the use of taps, probes and transducers for measurement of static and stagnation pressures in nominally steady, compressible (subsonic and supersonic) flows. In addition, it includes the use of the schlieren technique to visualize shock and expansion waves in supersonic flows. The various measurements are acquired in a supersonic, blowdown wind tunnel and a supersonic (converging/diverging) nozzle. The experiments also allows the student to experimentally investigate many interesting and important aspects of the behavior of supersonic flows.

#### Background

##### Measurement Instrumentation

**Pressure Measurements** - Steady pressures are most conveniently and accurately measured using static taps or probes, and stagnation pressure probes. This is the approach used in this laboratory. Static taps and probes, as well as total or stagnation pressure probes (see Figure 1), have been introduced in earlier labs. Typically taps and probes are located quite a distance from the actual pressure transducer, thus they have a relatively slow response. Rapidly fluctuating pressures must be determined using other devices, such as microphones or piezoelectric transducers as covered in previous labs.

a) Gravitational Transducers - Transducers that can be used to measure pressure include gravitational transducers, such as mercury or oil manometers. Manometers can be of various shapes, including standard U-shaped tubes and straight long vertical tubes attached to a liquid filled reservoir. Manometers measure relative pressures, specifically the pressure difference between the two ends of the tube. For measurement of stagnation pressures in compressible flows, which can easily exceed 1 atm, long tubes are required (even for a dense liquid such as mercury, measurement of  $\Delta p=1$  atm requires at least a 30 inch long tube). For vertical tubes connected to a reservoir, pressures below atmospheric are measured by connecting the tubing

from the probe to the upper, open end of the manometer tube while the reservoir is open to the atmosphere (Figure 2a). Thus, the lower the value of the static pressure, the higher the mercury column in the manometer. On the other hand, if the pressure to be measured exceeds atmospheric (e.g., the total pressure in a blowdown type supersonic tunnel), the tubing from the probe is attached to the reservoir and the upper end of the manometer is left open (Figure 2b). If one is dealing with a manometer bank containing a number of tubes, the level in the reservoir drops as the mercury rises in the tubes. This must be compensated for by measuring the drop in level in a reference tube which is open to atmosphere (Figure 2c).

b) Elastic Transducers - Another family of pressure measurement devices can be categorized as elastic transducers. In these devices, a deflection or deformation accompanying a balance of pressure and elastic forces is used to measure pressure. A classic example of an elastic pressure transducer is the Bourdon tubes (Figure 3) commonly found in pointer type pressure gages. In these devices an oval section tube is initially coiled into a circular arc. As a pressure is applied to the tube, the oval section tends to become more circular in cross-section. Since the inner and outer lengths of the tubes remain approximately the same as their initial values, the primary result of the applied pressure is an uncoiling of the arc. The uncoiling is coupled to the motion of a pointer, which is used to determine the pressure.

Another type of elastic transducer is the diaphragm type, where the pressure force causes a diaphragm to deflect. Examples of this type include Barocell/Barotron type transducers, in which the pressure deflects a thin diaphragm that forms one plate of a capacitor. Different pressures yield different capacitances that are converted to electrical voltages (and read using a voltmeter in this lab). Barocells and Barotrons typically provide very sensitive measurements of pressure, e.g., Torr/volt, with the calibration (sensitivity) usually supplied by the manufacturer. Other methods can be used to measure the change in the diaphragm, for example resistance strain gages can be applied to the diaphragm surface, and the measured strain can be related to the applied pressure through calibration. Relatively inexpensive transducers can be made by using semiconductor materials. In this case, the semiconductor resistors are “written” as a bridge circuit directly onto a substrate (e.g., silicon) that acts as the diaphragm. The strain on the semiconductor results in a change in semiconductor resistance; this is known as the *piezoresistive effect*. The change in semiconductor resistance is analogous to the change in metal resistors (recall the strain gauges used in the force balance

experiments), except in the latter, the change in resistance is *primarily* due to the change in the metal resistor's cross-sectional area as it is strained. For semiconductor materials, the resistance change is related to other changes in the internal structure of the semiconductor. This type of silicon diaphragm transducer will be used to make differential pressure measurements in the converging-diverging nozzle experiment.

**Flow Visualization** - Sudden changes in the density of a gas and the resulting gradient in refractive index can be visualized using the schlieren technique. Such steep refractive index gradients exist, for example, in flames or in shock waves. In this laboratory, shock waves, whose properties will be discussed in the next section, are visualized using schlieren imaging. In this technique (see Figure 4), the light from a source is allowed to expand and is then collimated using a large diameter, long focal length (typically biconvex) lens. The resulting parallel beam is then passed through the test section of the wind tunnel before being refocused using a second biconvex lens of similar optical properties to those of the first. A stop placed at the focal point of the second lens blocks all of the undeflected light. However, any light rays that have been refracted in the test section by a refractive index gradient caused by, for example, a shock wave are no longer parallel to the optical axis of the system. These rays will, therefore, be focused at a different location in the focal plane of the second lens and will, thus, bypass the schlieren stop. A focusing lens is then used to create an image of the test region on a screen or photographic plate using only the refracted light. This image displays only those regions of the flow in which a steep refractive index gradient exists, i.e., the shock wave.

### Fluid Mechanics

A brief description of compressible flows (summarizing important details covered in AE 3450) is given below. It is important to note that **inviscid flow** will be assumed throughout this discussion. When a gas, such as room temperature air, flows at velocities greater than approximately 100 m/s (or for Mach number  $M > 0.3$ ), the density changes of the gas *due to changing Mach number* become significant, i.e., the flow becomes *compressible*. This results in some unexpected phenomena, especially at supersonic speeds. For example for flow in a nozzle,  $M$  increases as the cross-sectional area of the nozzle decreases, and vice versa, as long as the flow is subsonic. This could have been anticipated from incompressible flow considerations, although, once the flow becomes compressible the area-velocity relationship is no longer linear since the density also changes. Once the flow becomes supersonic, however, the density decreases so rapidly with increasing Mach number that the Mach number actually

*increases* with increasing nozzle area, and vice versa. Furthermore, it turns out that an adiabatic flow can only increase from subsonic to supersonic speeds if the transition from  $M < 1$  to  $M > 1$ , (i.e.,  $M = 1$ ) occurs at the throat (minimum area) of a nozzle.

Bernoulli's equation, which was derived assuming constant density is no longer valid for compressible flow. Instead, the relationship between the static and stagnation pressures, e.g.,  $p/p_o$ , as a function of Mach number may be obtained for a calorically perfect gas (constant specific heats) from the following (more general) expression.

$$\frac{p_o}{p} = \left[ 1 + \frac{\gamma - 1}{2} M^2 \right]^{\gamma / \gamma - 1} \quad (1)$$

As long as the flow remains *isentropic*, the *stagnation pressure is constant* everywhere. The static pressure, on the other hand, decreases as the Mach number increases since more potential energy, which gives rise to the static pressure, is now converted to kinetic energy. This is true for subsonic as well as supersonic flow.

Let us now consider the flow in a converging-diverging nozzle (see Figure 5) connected to a high pressure supply at one end and open to the atmosphere at the other. As the pressure in the supply (reservoir pressure) is increased, air begins to flow through the nozzle. As long as the flow in the nozzle is everywhere subsonic, the Mach number increases in the converging part (region A) and decreases in the diverging part (region B) of the nozzle. The static pressure level in the nozzle behaves inversely as the magnitude of the Mach number. Thus for subsonic flow in the nozzle, the static pressure drops in the converging section and rises in the diverging section. At the exit of the nozzle, the flow should reach equilibrium with the back pressure (given by the local atmospheric pressure in this example). As the reservoir pressure is increased further, the mass flow rate through the nozzle increases, causing a change in Mach number and, thus, in static pressure. The Mach number in the converging part of the nozzle can keep increasing in this manner until the Mach number at the nozzle throat reaches unity. The nozzle is then called “**choked**”. The Mach number in region A can no longer be affected by increasing the reservoir pressure (or decreasing the back pressure), and the mass flow rate, *for fixed upstream stagnation conditions*, is a maximum once the flow is choked.

Increasing the reservoir to back pressure ratio ( $p_o/p_b$ ) above the value that corresponds to choking does, however, affect the flow conditions in region B. Beyond the choking condition,

the flow downstream of the throat begins to go supersonic and increases in Mach number as the nozzle flow expands. However,  $p_o/p_b$  is not yet high enough to result in completely supersonic (isentropic) flow throughout the entire region B. The flow adjusts to these conditions by suddenly reverting back to subsonic flow in a normal shock somewhere in the expanding part of the nozzle. Across this shock wave the static pressure rises. Behind the shock the flow is subsonic, and, therefore, decreases in Mach number as the nozzle continues to increase in area. The static pressure rises correspondingly until the back pressure is reached at the exit of the nozzle. As  $p_o/p_b$  is raised still further, the position of the shock wave moves towards the nozzle exit, until eventually there is no shock *in* the nozzle.

The presence of the shock wave changes all flow conditions across it except the stagnation temperature (or, more precisely, the stagnation enthalpy) since across the shock the flow is adiabatic. The extent of the influence of the shock upon the flow conditions depends upon the Mach number of the flow going into the shock. For thermally and calorically perfect gases, the ratio of the static pressures across the shock ( $p_2/p_1$ ) as a function of Mach number ahead of the shock ( $M_1$ ) are given by

$$\frac{p_2}{p_1} = \frac{2\gamma M_1^2 - (\gamma - 1)}{(\gamma + 1)} \quad (2)$$

and the stagnation pressure ratio  $p_{o2}/p_{o1}$  is

$$\frac{p_{o2}}{p_{o1}} = \left\{ \frac{\gamma + 1}{2} \frac{M_1^2}{1 + \frac{\gamma - 1}{2} M_1^2} \right\}^{\frac{\gamma}{\gamma - 1}} \left\{ \frac{2\gamma}{\gamma + 1} M_1^2 - \frac{\gamma - 1}{\gamma + 1} \right\}^{\frac{1}{1 - \gamma}} \quad (3)$$

where we have assumed a stationary shock for the stagnation pressure ratio.

If a supersonic flow encounters a solid body, part of the flow must be decelerated to stagnation conditions. Since this necessarily involves a transition from supersonic to subsonic flow, a shock stands ahead of the body. This shock provides the mechanism for the transition. In the case of a thin probe in supersonic flow a small, normal shock stands ahead of the probe tip (Figure 6a). A conically shaped bow shock trails from the normal shock. The bow shock weakens as one moves away from its leading edge and, eventually, turns into a Mach wave across which the flow properties no longer change significantly. Therefore, the stagnation

pressure measured using a Pitot probe in supersonic flow is that *behind* a normal shock. In a static probe, on the other hand, the orifice is located far downstream of the probe tip. The effect of the normal shock is then no longer felt and the static pressure measured is essentially equal to that ahead of the shock. If the probe is replaced by a wedge (Figure 6b) a pair of oblique shocks is formed that attach to the tip of the wedge. The relationship between the flow Mach number and the half angles of the shock and of the wedge are plotted in Figure 7.\*

### Flow Facilities

**CD Nozzle** - This set of experiments is to be carried out in a converging-diverging (CD) nozzle made of Plexiglas (see Figure 5). The upstream side of the nozzle is attached to a high pressure supply (regulated so as not to exceed ~50 psig); the downstream side is connected to a settling chamber and an acoustic muffler before exiting into the room. Between the nozzle and the high pressure supply is a manual valve. The stagnation pressure entering the nozzle is controlled by the setting of this valve (and the pressure downstream of the valve can be monitored using a simple Bourdon tube type gauge). The nozzle is instrumented with two Pitot probes along the axis and eight static pressure taps along the wall. The first Pitot probe is located at the nozzle throat. The second probe is located near the last static pressure port in the nozzle (station 7). As shown in Figure 5, one static pressure tap is located ahead of the nozzle throat, the second at the throat and five taps are located at one half inch intervals along the expanding part of the nozzle. Tap number eight measures the back pressure. The ten pressures will be measured by ten piezoresistive, silicon diaphragm transducers and recorded by a computer data acquisition system. Since some of the pressure gauges can be damaged by operation outside their pressure range, please carefully listed to any guidelines given by the TA's with respect to the maximum pressure you should allow the CD inlet to reach.

**Blowdown Tunnel** - In this facility, air from a large tank at approximately 120 psi is passed through a pressure regulator and a large, manual (butterfly) valve and into a supersonic tunnel of rectangular cross-section. The tunnel (Figure 8) consists, essentially, of a nozzle (2" × 1.778" at its throat) and a test section (2" × 3"). The test section walls are fitted with two parallel windows in order to provide optical access. The tunnel is instrumented with a Pitot probe upstream of the nozzle and a Pitot as well as a static pressure probe in the test section.

---

\*Similar plots can be found in most texts on compressible flow.

The orifice of the static pressure probe is aligned with the tip of the Pitot probe in the test section. The Pitot probe upstream of the nozzle is connected to a pressure gauge (which records gage pressure). The downstream Pitot probe can be connected to the Baratron for comparison to the ambient pressure. Similarly, the static pressure probe can be connected to the Baratron while the other side is open to atmosphere. Atmospheric pressure is measured using an electronic barometer. The probes in the test section may be removed and replaced by a wedge or by a solid body of some other configuration. A schlieren system (Figure 9) is configured around the test section of the tunnel. A single lens is used to perform both the focusing of the collimated light and to image the test section on the screen. Also, a bicolor filter with an opaque band in the middle is used to produce the schlieren stop. Rays that pass above and below the focal point of the second lens pass through different colored filters. Thus rays that were deflected upwards will show up in one color in the image, while rays that were deflected downward will be a different color.

Although the tunnel is fed from a large tank, running times are limited. It is, therefore, important to coordinate the measurements to be made before starting the tunnel. It is a good idea to watch the upstream stagnation pressure to make sure that it is not dropping with time (which would happen if you were overdraining the supply tanks). Since the Mach number in the tunnel depends only upon the area ratio of nozzle to test section (as long as the upstream pressure is sufficient to choke the nozzle), the test section Mach number is not affected by any pressure drop, but your pressure measurements will change.

## CD Nozzle Measurements

### Procedure

1. Calibrate the differential silicon pressure transducers. **Record** (with the computer) voltage outputs for all the transducers at **three differential** (or in this case, gage) pressures, including 0 atm and  $\sim 1$  atm. You will use a small pressurized tube connected to a simple, pointer-type pressure gauge - this will act as your calibration reference. There will be ten tubes, connect one to the higher pressure port (labeled  $P_2$ ) on each of the pressure transducers. You will need to also **record** (manually) the local atmospheric pressure in the room.
2. Connect the transducers to the CD nozzle pressure probes and taps. For most of the

transducers, leave the low pressure port ( $P_1$ ) open to the atmosphere and connect the high pressure port to the probes and static taps. This is because most of the time, the pressures in the nozzle are above ambient. Initially however, you will need to reverse this for the static ports at stations 1 and 2 (i.e., connect these taps to the low pressure port,  $P_1$ ). At the very subsonic conditions, your reservoir (stagnation) pressure is not much higher than ambient, so your internal pressures can go below ambient.

3. Be sure the second Pitot probe is normal to the flow (look through the Plexiglas).
4. Start the real-time computer display of the pressures (the “virtual manometer bank”).
5. Make sure the pressure gage at the pressure regulator (if it is connected) is reading  $\sim 50$  psig.
6. Open the valve slightly to permit **subsonic flow throughout the nozzle**. Use the computer to **record** the pressures in the nozzle. After you are finish recording the subsonic case, switch the pressure taps for stations 1 and 2 from the low pressure ports ( $P_1$ ) to the high pressure ports ( $P_2$ ).
7. Open the valve further until the **flow is just choked**, i.e., throat has just reached Mach 1. You should be able to determine this by watching the pressure display on the computer. *You may also hear a distinct change in the noise from the nozzle.* Use the computer to **record** the pressures.
8. Continue opening the valve until a **shock is observed between stations 4 and 5**. You will be able to detect the shock location by a change in sign in the pressure gradient in region B of the nozzle. Once again, **record** all pressures with the computer system.
9. **Continue opening the valve** until the shock passes station 6. The flow in most of the expanding part of the nozzle should now be supersonic. **Record** all pressures using the computer.
10. **Repeat** steps 6 - 8. This will provide data to assess repeatability. When you are done, **quickly shut the valve completely**.

#### Data Reduction

1. Determine the sensitivity (slope) and null (zero offset) values for each pressure transducer, based on a linear best fit to your calibration data.

2. Convert all of the transducer readings to **absolute** pressure. These will be required for later calculations and plots.
3. Calculate the Mach numbers at stations 1 and 2 from the static and stagnation pressures determined at these locations for the following three conditions:
  - a. subsonic flow throughout the nozzle;
  - b. the “just choked” condition; and
  - c. the condition where the shock stands between stations 4 and 5.
4. Calculate the Mach number at station 6 for supersonic flow in two ways:
  - a. using the static pressure at station 6 and a suitable stagnation pressure; and
  - b. using the stagnation pressures as measured by the Pitot probes located at the throat (station 2) and at station 7.

Note - be sure to use the correct value of the stagnation pressure in these calculations. It will be helpful to sketch for yourself a diagram of the nozzle indicating the position of the pressure taps and probes and the location of the shock wave.

#### Results Needed For Report

1. Make a table of the sensitivity and zero offset values for each pressure transducer.
2. Make a table listing:
  - a. atmospheric pressure; and
  - b. the stagnation pressure measured using the two Pitot probes for the cases of:
    - i) subsonic flow;
    - ii) a shock between stations 4 and 5; and
    - iii) supersonic flow through at least station 6.
3. Make a table listing the Mach numbers at stations 1 and 2 for the three conditions specified under Data Reduction step 3.
4. Make a table listing the Mach number at station 6 as calculated by the two methods given under Data Reduction 4.

5. Make a graph with axial distance as the abscissa and the ratio of local static pressure to supply stagnation pressure as the ordinate. On this single graph, plot the results for the static pressure measurements for the conditions of:
  - a. subsonic flow;
  - b. a shock between stations 4 and 5; and
  - c. supersonic flow through at least station 6.

Using different symbols, plot the repeated data on this graph as well. This will show the quality of the repeatability.

6. Make a plot like that described in step 5 above, except plot Mach number as the ordinate.

### **Blowdown Tunnel Measurements**

#### Procedure

1. Make sure the test section Pitot probe is connected to the high pressure port of the Baratron (the low pressure port should be open to the atmosphere). Turn the tunnel on (*by opening the upstream valve*) and then observe the upstream stagnation pressure (on the pressure gauge) as it slowly changes. When this pressure reaches a prearranged value (~14-15 psig, ask the TA), **record** the upstream and downstream stagnation pressures. Turn off the tunnel, remove the tubing from the Pitot probe port and connect the static pressure probe to the Baratron. Then repeat the above procedure (i.e., record the upstream stagnation probe pressure and the test section static probe pressure). You will need to also **record** (manually) the local atmospheric pressure in the room.
2. Replace the probes from the test section and replace them with the variable area diffuser. Measure the minimum diffuser area required to start the tunnel. Do this by increasing the area of the adjustable throat until it can “swallow” the shock from the test section. You can tell when the shock is swallowed by how the adjustment screw “feels”. Remove the diffuser and **measure the throat area** with a pair of calipers.
3. Remove variable area diffuser and replace it with the wedge. Connect one of the static pressure ports on the wedge to the high pressure port of the Baratron (the low pressure port should be open to the atmosphere). **Make sure the cooling air is flowing to the light source**, then turn on the light source of the schlieren system. (*Avoid switching the*

*light source on and off unnecessarily, since this will shorten the life of the source.)* A shadow of the wedge should now be observed on the screen. Be sure the orientation of the wedge is parallel to the tunnel floor. **Trace** the shape of the wedge on a piece of tracing paper.

4. **Turn on the tunnel.** A shock wave supported by the wedge should now be visible (along with other waves). **Trace** the shape of the shock (and other features of interest) on the same tracing paper. You may also wish to note the color of each of the waves. In addition, **record the static pressure** on the wedge surface using the Baratron.
5. *Turn off the tunnel.* This piece of tracing paper will be scanned by the TA's, so **add** two orthogonal scales (like rulers) to make sure the scanning process does not alter the aspect ratio of the image.
6. Turn off the schlieren light source.
7. Remove the wedge and reinstall the probes in the test section and get the facility ready for the next group.

#### Data Reduction

1. Calculate the test section Mach number from the ratio of static to stagnation pressure in the test section. Be very careful to use the correct, measured stagnation pressure. A rough sketch of the position of the probes and the location of the shock may help you.
2. Calculate the test section Mach number using the measured stagnation pressures and the shock equations (listed in the Background section) or appropriate shock tables.
3. Determine the Mach number in the test section using the values of the half angles of the wedge and the shock that you measured. Use Figure 7 or similar graphs from your compressible flow texts.
4. Calculate the theoretical minimum diffuser area required to start the tunnel.

#### Results Needed For Report

1. Make a schematic of the various configurations of tubing used in the pressure measurements.
2. Make a table listing the test section Mach number as calculated by using:

- a. the ratio of static to stagnation pressure in the test section;
  - b. the measured stagnation pressures in the test sections; and
  - c. the shock angle on the wedge.
3. Compare the calculated and measured values of the minimum diffuser throat area required for starting this tunnel. (Be sure to explain observed differences in the appropriate section of your report.)

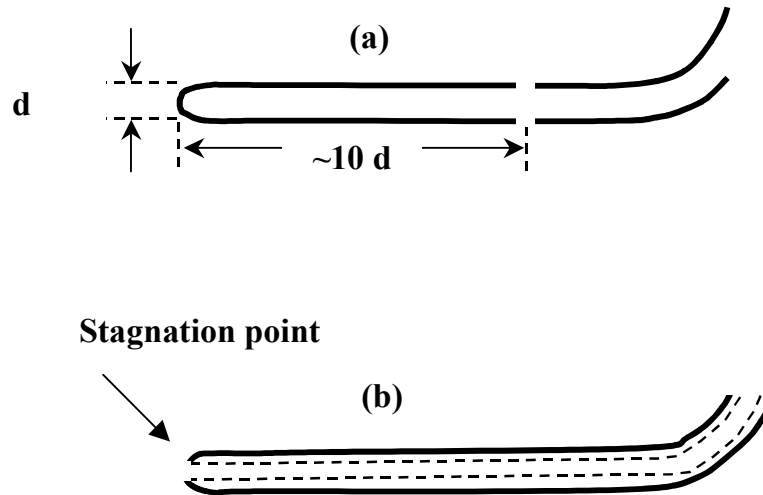

**Figure 1.** Schematic of a) static and b) Pitot pressure probes.

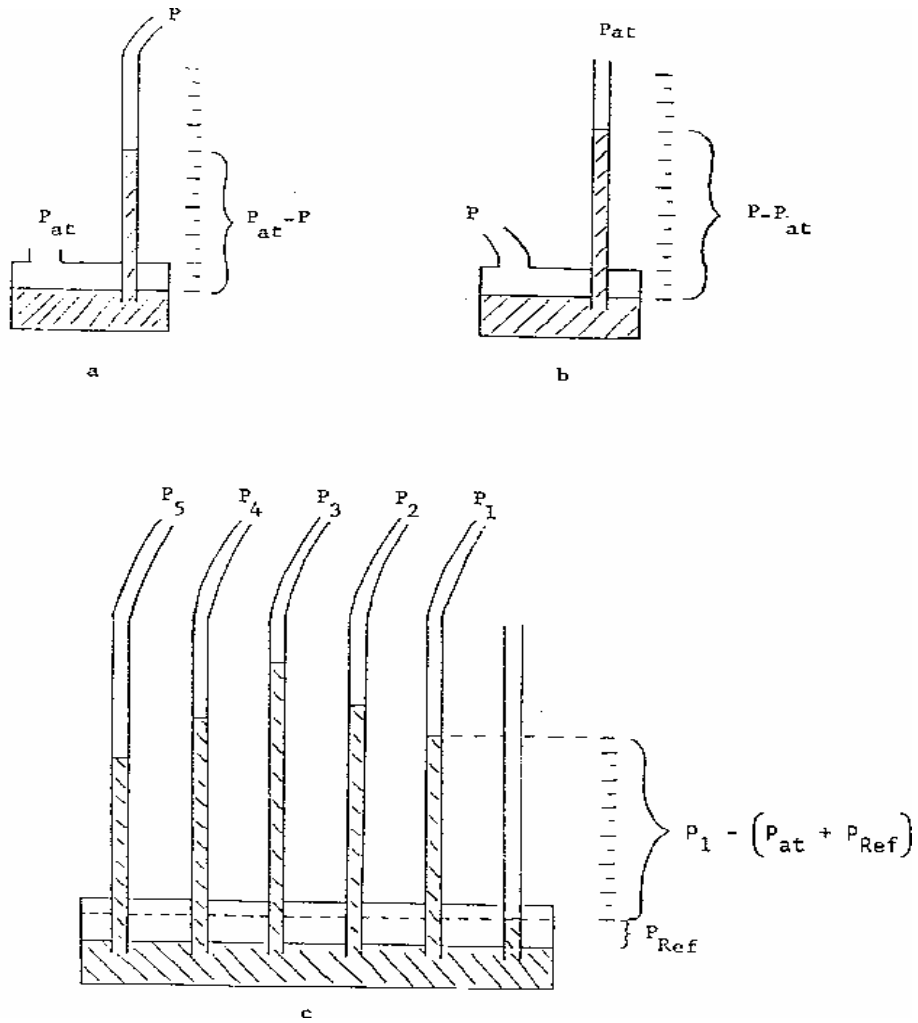

**Figure 2.** Schematic of vertical type manometers: a)  $p < p_{at}$ , b)  $p > p_{at}$ , and c) a manometer bank (with  $p_{at}$ =ambient pressure).

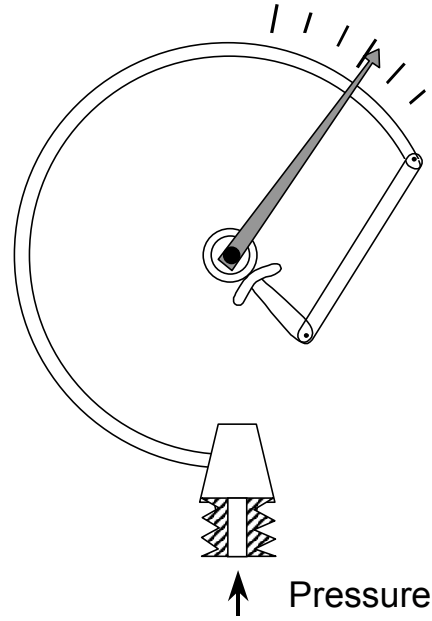

Figure 3. Basic Bourdon-type pressure transducer.

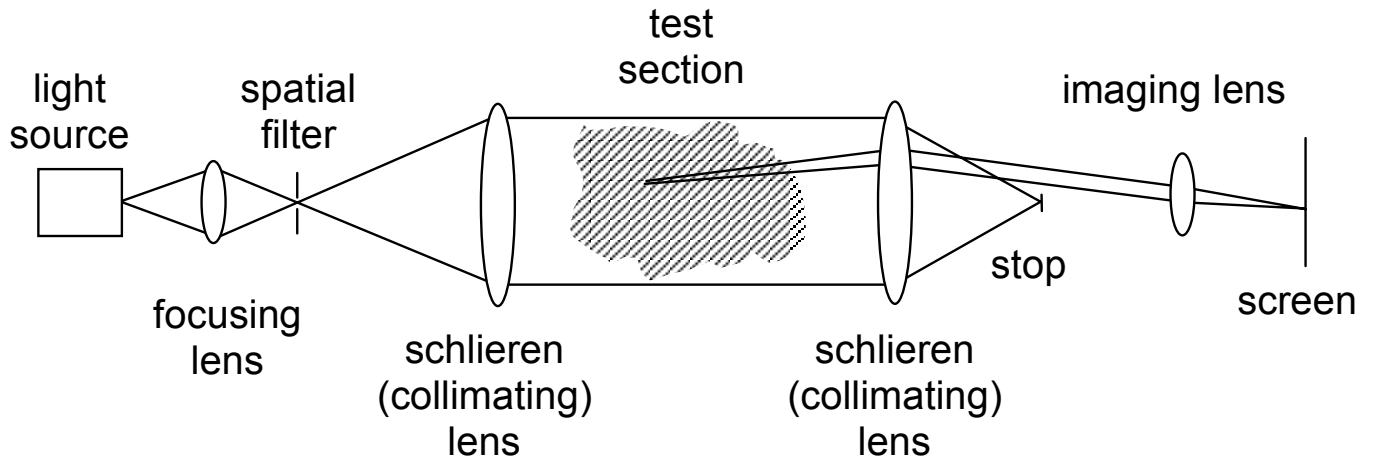
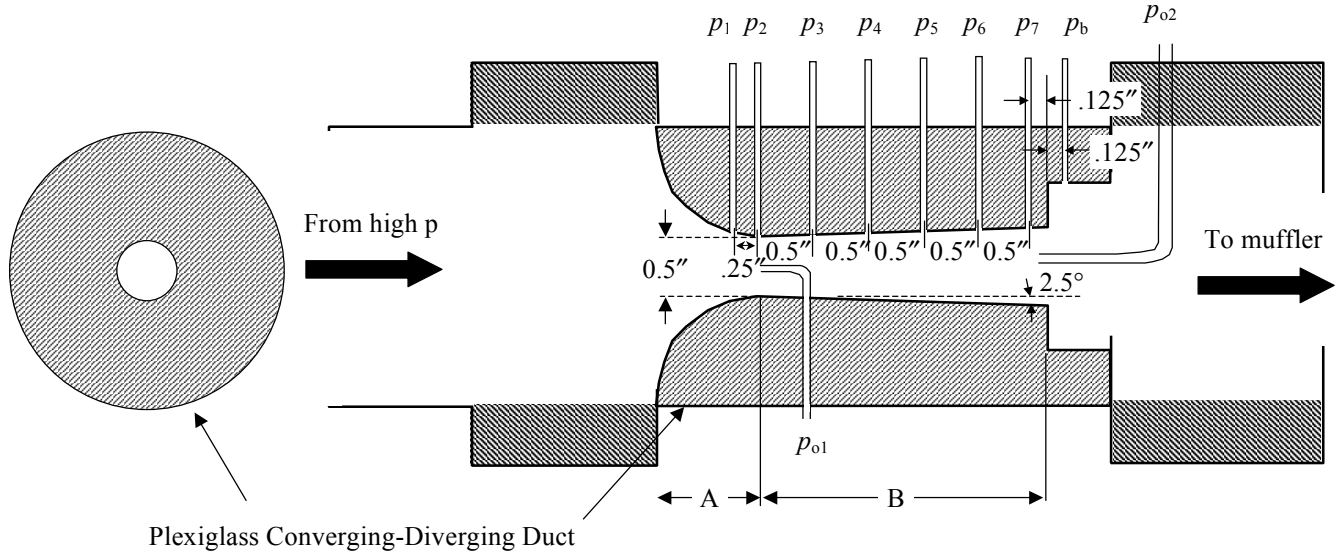
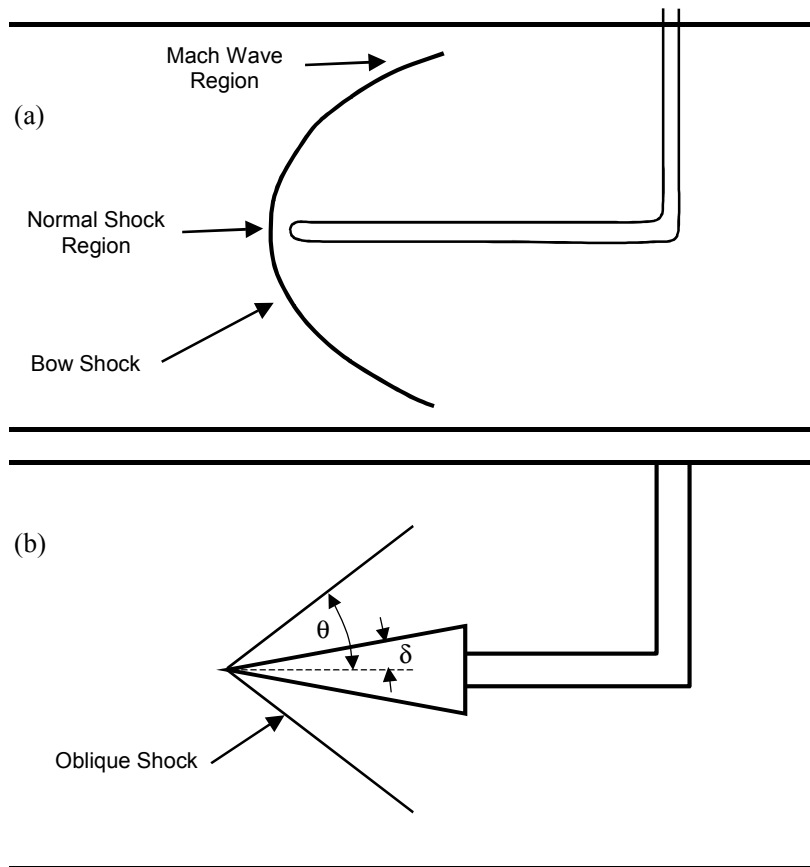

Figure 4. Schematic of a typical schlieren setup.



**Figure 5.** Schematic of the converging-diverging nozzle showing location of pressure probes and taps (throat at  $p_2$ ).



**Figure 6.** Schematic of shock on: a) probe and b) wedge in supersonic flow ( $\theta$  = shock half angle,  $\delta$  = wedge half angle).

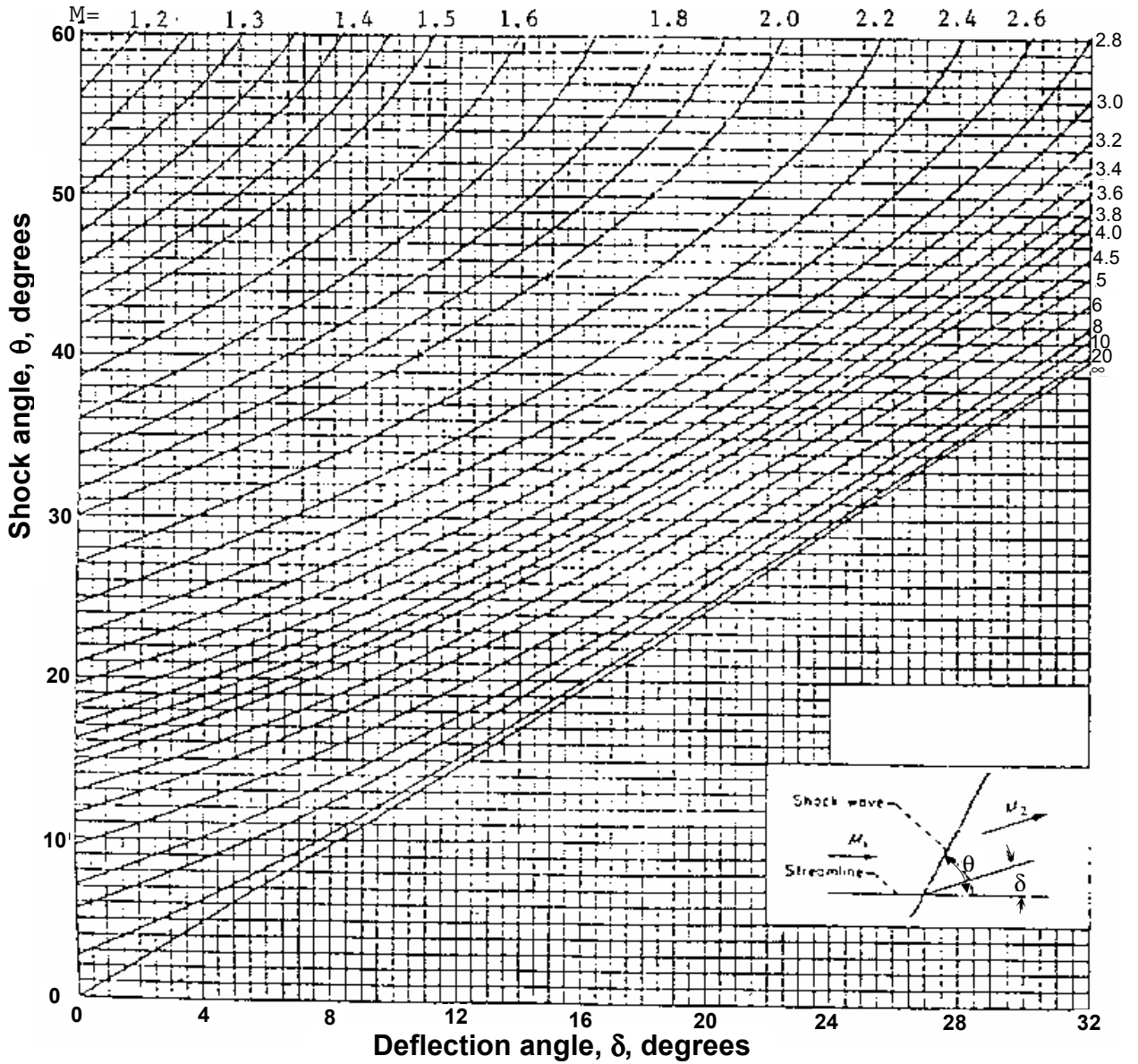

**Figure 7.** Variation of shock-wave angle with flow-deflection angle for various upstream Mach numbers for a thermal and calorically perfect gas with  $\gamma = 1.4$ .

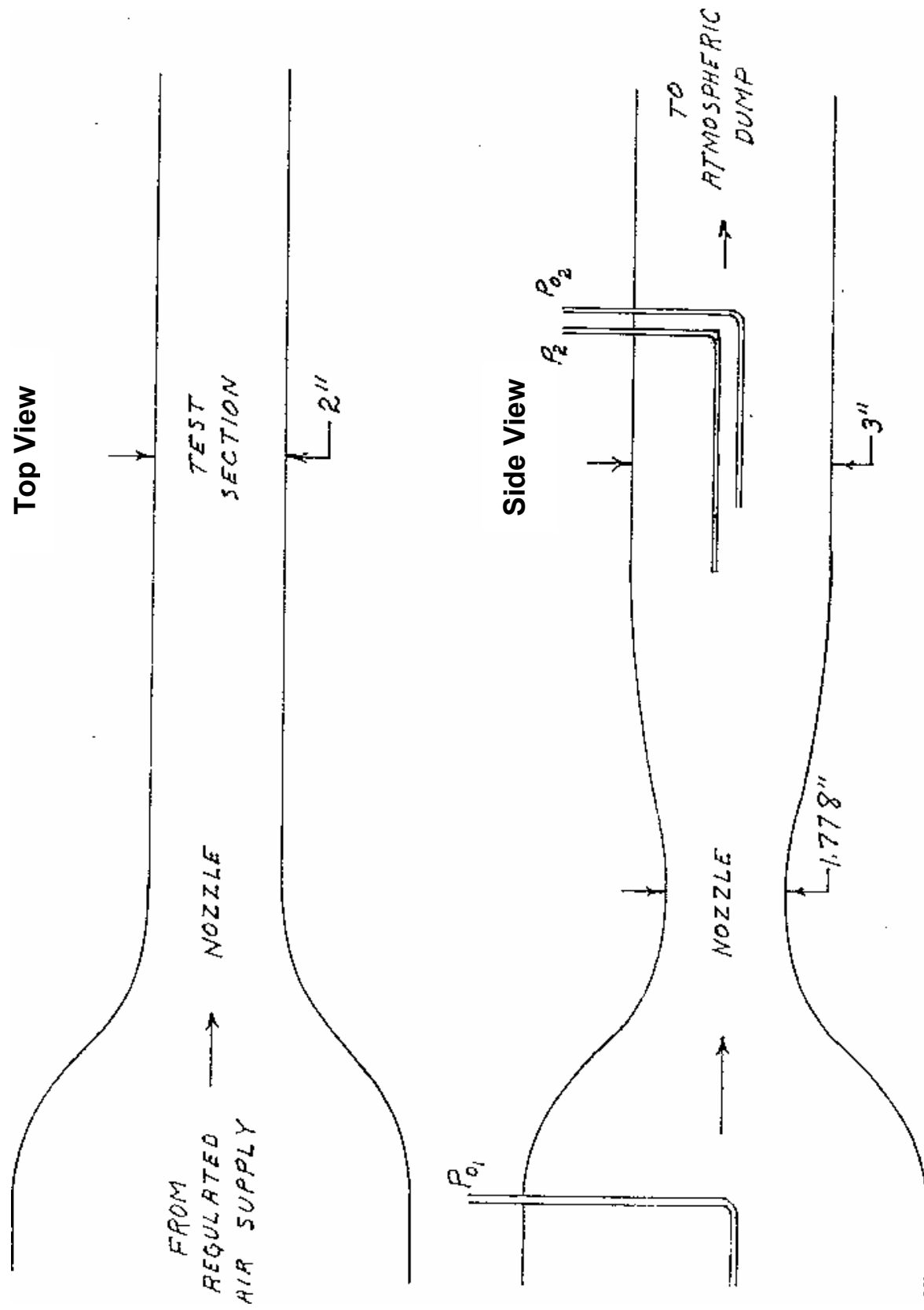
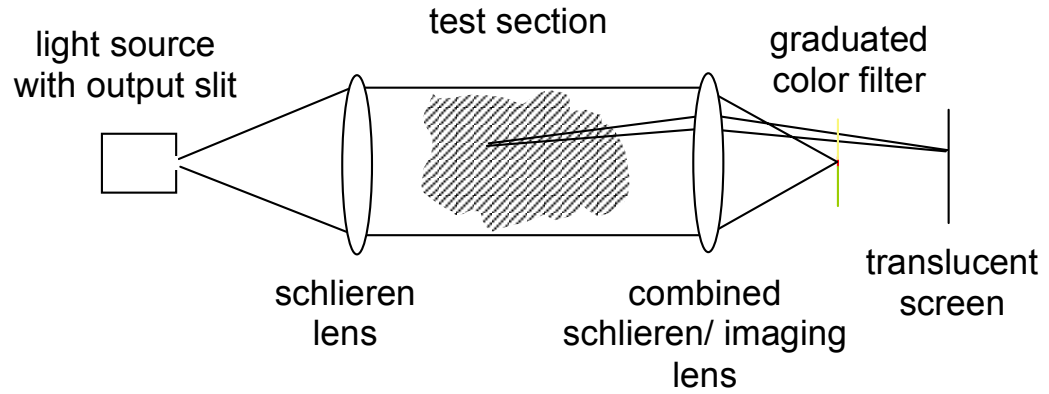

Figure 8. Schematic of supersonic blowdown tunnel.



**Figure 9.** Schematic of schlieren setup attached to “2-d” blowdown windtunnel. The graduated color filter has a dark red pattern in the center that acts as the schlieren stop.